

# RCP4-SA7C

ROBO Cylinder, Slider Type, Motor Unit Coupled, Actuator Width 73mm, 24-V Pulse Motor

Model Specification Items	<b>RCP4</b> — <b>SA7C</b> — <b>I</b> — <b>56P</b> — □ — □ — <b>P3</b> — □ — □
Series	Type — Encoder type — Motor type — Lead — Stroke — Applicable controller — Cable length — Options
	I: Incremental specification    56P: Pulse motor, size 56□    24: 24mm    16: 16mm    8: 8mm    4: 4mm    50: 50mm    ?    800: 800mm (every 50mm)    P3: PCON-CA    MSEP-C    N: None    P: 1m    S: 3m    M: 5m    X□□: Custom length    R□□: Robot cable    See Options below.

\* See page Pre-47 for details on the model descriptions.



Technical References Appendix P.5



- The maximum payload is the value when operated at 0.3G (0.2G with some models) acceleration. The upper limit of acceleration is 1 G (\*). Note that raising the acceleration causes the payload to drop. (\*The specific value varies depending on the connected controller and actuator lead. For details, refer to "Selection References" on page A-100 and A-102.
- Take note that the maximum payload and maximum speed vary depending on the controller connected to the RCP4. (Refer to the actuator specifications below.)
- See page A-71 for details on push motion.

### Correlation Diagrams of Speed and Payload

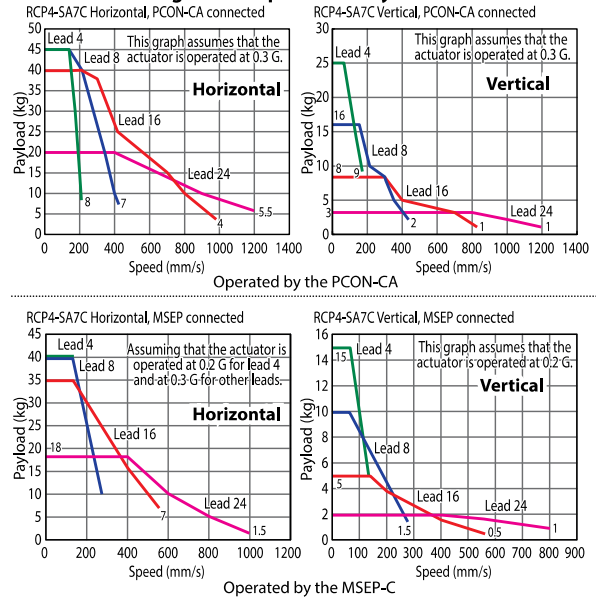

### Actuator Specifications

#### Leads and Payloads

(\*) When operated at 0.2 G

Model number	Lead (mm)	Connected controller	Maximum payload		Stroke (mm)
			Horizontal (kg)	Vertical (kg)	
RCP4-SA7C-I-56P-24-①-P3-②-③	24	PCON-CA	20	3	50~800 (every 50mm)
		MSEP-C	18	2 (*)	
RCP4-SA7C-I-56P-16-①-P3-②-③	16	PCON-CA	40	8	
		MSEP-C	35	5 (*)	
RCP4-SA7C-I-56P-8-①-P3-②-③	8	PCON-CA	45	16	
		MSEP-C	40	10 (*)	
RCP4-SA7C-I-56P-4-①-P3-②-③	4	PCON-CA	45	25	
		MSEP-C	40 (*)	15 (*)	

Code explanation ① Stroke ② Cable length ③ Options \* See page A-71 for details on push motion.

#### Stroke and Maximum Speed

The values in <> apply when the actuator is used vertically.

Lead (mm)	Connected controller	50~450 (every 50mm)	500 (mm)	500 (mm)	600 (mm)	650 (mm)	700 (mm)	750 (mm)	800 (mm)
24	PCON-CA	1200							
	MSEP-C	1000<800>				890<800>			
16	PCON-CA	980<840>		865<840>		750	655	580	515
	MSEP-C	560							
8	PCON-CA	490		430	375	325	290	255	255
	MSEP-C	280							
4	PCON-CA	245<210>		215<210>		185	160	145	125
	MSEP-C	140							

\* The values of lead 8 and lead 4 apply when acceleration is at 0.1G. (unit: mm/s)

#### ① Stroke

Stroke (mm)	Standard price	Stroke (mm)	Standard price
50	—	450	—
100	—	500	—
150	—	550	—
200	—	600	—
250	—	650	—
300	—	700	—
350	—	750	—
400	—	800	—

#### ② Cable Length

Type	Cable symbol	Standard price
Standard type	P (1m)	—
	S (3m)	—
	M (5m)	—
Special length	X06 (6m) ~ X10 (10m)	—
	X11 (11m) ~ X15 (15m)	—
	X16 (16m) ~ X20 (20m)	—
	R01 (1m) ~ R03 (3m)	—
Robot cable	R04 (4m) ~ R05 (5m)	—
	R06 (6m) ~ R10 (10m)	—
	R11 (11m) ~ R15 (15m)	—
	R16 (16m) ~ R20 (20m)	—
	R16 (16m) ~ R20 (20m)	—

\* See page A-59 for cables for maintenance.

#### ③ Options

Name	Option code	See page	Standard price
Brake	B	→ A-42	—
Optional cable exit direction (top)	CJT	→ A-42	—
Optional cable exit direction (right)	CJR	→ A-42	—
Optional cable exit direction (left)	CJL	→ A-42	—
Optional cable exit direction (bottom)	CJB	→ A-42	—
Non-motor end specification	NM	→ A-52	—
Slider roller specification	SR	→ A-55	—

#### Actuator Specifications

Item	Description
Drive system	Ball screw ø12mm, rolled C10
Positioning repeatability (*1)	±0.02mm [±0.03mm]
Lost motion	0.1mm or less
Base	Material: Aluminum, white alumite treated
Guide	Linear guide
Allowable dynamic moment (*2)	Ma: 13.9 N·m, Mb: 19.9 N·m, Mc: 38.3 N·m
Allowable overhang	230mm or less in Ma, Mb and Mc directions
Ambient operating temperature, humidity	0 to 40°C, 85% RH or less (Non-condensing)

(\*1) The value at lead 24 is shown in [ ].  
(\*2) Based on 5,000km of traveling life

Dimensional Drawings

CAD drawings can be downloaded from the website.

www.intelligentactuator.com

For Special Orders

Appendix P.15



- \*1 Connect the motor-encoder integrated cable here. \* See page A-59 for details on cables.
- \*2 During home return, be careful to avoid interference from peripheral objects because the slider travels until the mechanical end.  
ME: Mechanical end  
SE: Stroke end

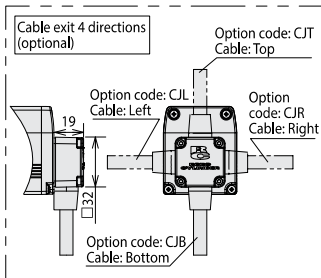
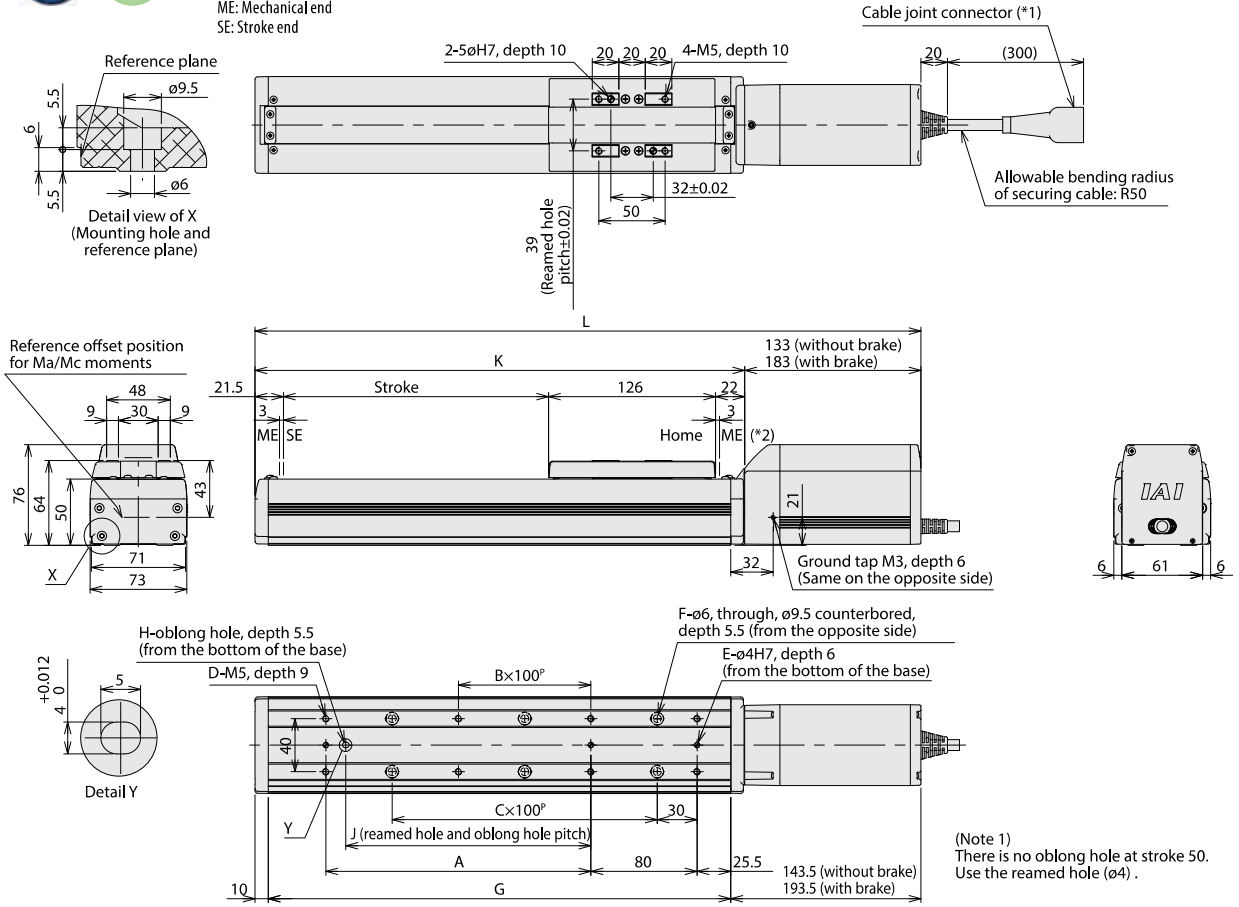

■ Dimensions and Mass by Stroke

Stroke	Dimensions and Mass by Stroke																
	50	100	150	200	250	300	350	400	450	500	550	600	650	700	750	800	
L	Without brake	352.5	402.5	452.5	502.5	552.5	602.5	652.5	702.5	752.5	802.5	852.5	902.5	952.5	1002.5	1052.5	1102.5
	With brake	402.5	452.5	502.5	552.5	602.5	652.5	702.5	752.5	802.5	852.5	902.5	952.5	1002.5	1052.5	1102.5	1152.5
A	0	100	100	200	200	300	300	400	400	500	500	600	600	700	700	800	800
B	0	0	0	1	1	2	2	3	3	4	4	5	5	6	6	7	7
C	1	1	2	2	3	3	4	4	5	5	6	6	7	7	8	8	8
D	4	6	6	8	8	10	10	12	12	14	14	16	16	18	18	20	20
E	2	3	3	3	3	3	3	3	3	3	3	3	3	3	3	3	3
F	4	4	6	6	8	8	10	10	12	12	14	14	16	16	18	18	18
G	199	249	299	349	399	449	499	549	599	649	699	749	799	849	899	949	949
H	0	1	1	1	1	1	1	1	1	1	1	1	1	1	1	1	1
J	0	85	85	185	185	285	285	385	385	485	485	585	585	685	685	785	785
K	219.5	269.5	319.5	369.5	419.5	469.5	519.5	569.5	619.5	669.5	719.5	769.5	819.5	869.5	919.5	969.5	969.5
Weight (kg)	Without brake	3.4	3.6	3.8	4.1	4.3	4.6	4.8	5.1	5.3	5.6	5.8	6.0	6.3	6.5	6.8	7.0
	With brake	3.9	4.1	4.3	4.6	4.8	5.1	5.3	5.6	5.8	6.1	6.3	6.5	6.8	7.0	7.3	7.5

Applicable Controllers

RCP4 series actuators can be operated with the controllers indicated below. Select the type according to your intended application.

Name	External view	Model number	Features	Maximum number of positioning points	Input power	Power supply capacity	Standard price	Reference page
Positioner type High-output specification		PCON-CA-56PI-①-2-0	Equipped with a high-output driver PIO control supported	512 points	DC24V	Refer to P618	—	→ P607
Pulse-train type High-output specification		PCON-CA-56PI-PL-①-2-0	Equipped with a high-output driver Pulse-train input supported	—				
Field network type High-output specification		PCON-CA-56PI-②-0-0	Equipped with a high-output driver Field network supported	768 points				
Solenoid valve multi-axis type PIO specification	MSEP-C-①-①-①-2-0	Positioner type based on PIO control, allowing up to 8 axes to be connected	3 points					
Solenoid valve multi-axis type Network specification	MSEP-C-①-①-②-0-0	Field network-ready positioner type, allowing up to 8 axes to be connected	256 points	Refer to P572	—	→ P563		

\*① indicates I/O type (NP/PN). \*② indicates number of axes (1 to 8). \*③ indicates field network specification symbol. \*□ indicates N (NPN specification) or P (PNP specification) symbol.